

BAXI

Baxi 11p
Baxi 14p

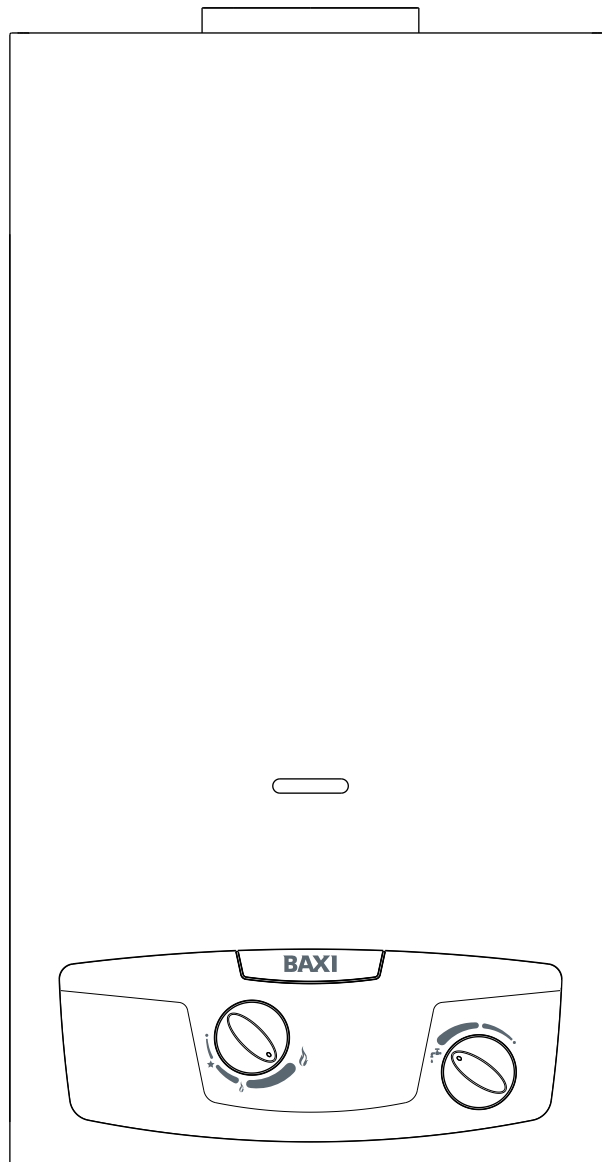

INSTALLATION, OPERATION AND MAINTENANCE MANUAL

The device is well built in accordance with the current legislation.

The CE sign positioned on the product indicates that it conforms to the following European Directives:

142/2009

93/68



0694
0694CP4791

WARNING

This booklet contains information relevant to the user as well as the installer.
The user must read the following chapters: General safety, Flue gas device and Operation.

INDEX

GENERAL SAFETY	pag. 4
1 TECHNICAL CHARACTERISTICS	pag. 4
1. a Technical Data	pag. 4
2 INSTALLATION	pag. 6
2. a Regulations	pag. 6
2. b Mounting to wall	pag. 6
2. c Room ventilation	pag. 6
2. d Gas Connection	pag. 6
2. e Water connection	pag. 7
2. f Disposal of waste product	pag. 7
2. g Gas transformation	pag. 7
3 OPERATION	pag. 9
3. a Operation	pag. 9
3. b Usage	pag. 9
4 MAINTENANCE	pag. 9
4. a Removing the casing	pag. 9
4. b Troubleshooting: Problems and solutions	pag. 10
5 SERIAL NUMBER PLATE	pag. 11

In parts of the manual the following symbols are used:











WARNING = for actions that require caution and adequate preparation











PROHIBITED = for actions that **MUST NOT** be performed

GENERAL SAFETY WARNINGS

The Operation Manual is an integral part of the product and so must be carefully preserved in order to accompany the product; if it is lost or damaged another copy can be requested from the Technical Assistance Centre.

-  The installation of the device and any other repairs or maintenance must be performed by qualified personnel according to the law in force, in compliance with the installing regulations including any revisions.
-  It is recommended that trained personnel install the device.
-  The device must be used according to the manufacturer specifications. The manufacturer cannot be held contractually or otherwise responsible for damage caused to persons, animals or objects as a result of incorrect installation, repair or maintenance or improper usage.
-  The product's safety or automatic regulation devices must not be modified unless performed by the manufacturer.
-  This device is intended for heating water and therefore must be connected to a water distribution network whose load and settings are compatible with the product.
-  If water spills, turn off the water supply and advise the qualified personnel at the Technical Assistance Centre.
-  If the machine is not used for prolonged periods turn off the gas supply. If there is a risk of the water freezing, empty the water heater.
-  If the machine breaks down or does not function properly, deactivate it, do not attempt to perform any repairs.
-  The machine's maintenance must be performed at least once a year: Book a maintenance session with the Technical Assistance Centre ahead of time to save wasting time and money afterwards.

When using the device the following safety rules must be applied:

-  Do not use the machine for purposes other than those intended by the manufacturer.
-  Do not block the intake and dissipation grills or the ventilation openings in the area where the device is installed with rags, paper or any other materials.
-  If a gas leak is detected, do not switch on any electrical devices, telephones or any other objects that could produce a spark. Ventilate the area by opening the doors and windows and switch off the gas supply.
-  Do not place objects on top of the device.
-  Do not leave flammable containers or substances in the area where the device is installed.
-  Do not attempt to repair the machine if it breaks down and/or works incorrectly.
-  Children or inexperienced persons are prohibited from using the device.
-  It is prohibited to open sealed elements.

To maintain the proper functioning of the device:

- Periodically clean the devices exterior with soapy water, this improves its appearance as well as preserving it from corrosion in the long term.
- Do not use solvents, powders or abrasive sponges.
- Do not clean the device and/or its parts with flammable materials (e.g. petrol, alcohol, diesel etc.).

The water heater package contains:

- 2 Two knobs to attach to the control panel after installation
- 1 Water filter to insert in the water valve pipe fitting.

1. TECHNICAL CHARACTERISTICS

1.a Technical Data

		Baxi 11p			Baxi 14p				
		kW		kcal/h	kW		kcal/h		
Nominal power usage (Pn)		19,0		16.340	23,7		20.374		
Nominal Thermal range (Qn)		21,8		18.748	27,2		23.392		
Minimal power usage (Pm)		7,5		6.424	7,5		6.424		
Minimal Thermal range (Qm)		9,0		7.740	9,0		7.740		
GAS TYPE		METHANE GAS		LIQUID GAS		METHANE GAS		LIQUID GAS	
		G20	G30	G31	G20	G30	G31		
P.C.I. (15° C 1013 mbar)	MJ/m3	34,02	116,09	88	34,02	116,09	88		
W.I. (15° C 1013 mbar)	MJ/m3	45,67	80,58	70,69	45,67	80,58	70,69		
Nominal feed pressure	mbar	20		28-30	20		28-30	37	
Consumption	m3/h	2,31		-	2,88		-	-	
	kg/h	-		1,72	-		2,14	2,11	
Burner Pressure	mbar	12,20		27,50	13,00		27,00	34,30	
Ø pilot flame nozzle	mm	0,28		0,16	0,28		0,16		
Ø main burner nozzle	mm	1,18		0,71	1,18		0,72		
nozzles	N.	11			13				
Ø gas connection		1/2"			1/2"				
Maximum flue gas load	g/s	13,20		12,40	18,40		17,70	19,00	
flue gas temperature	°C	185		180	168		163	158	
Category		II2H3+							
WATER		Baxi 11p			Baxi 14p				
Input range	l/min	select. min. da 2,5 a 5		select. max da 5 a 10,8	select. min. da 2,5 a 6,7		select. max da 6,7 a 13,6		
Water temperature elevation	°C	approximately 50		approximately 25	approximately 50		approximately 25		
Minimum pressure	bar	0,2			0,2				
Nominal pressure	bar	2			2				
Maximum pressure	bar	10			10				
Ø Water connections		1/2"			1/2"				
Ø flue gas release tube	mm	110			130				
DIMENSIONS AND WEIGHTS		DEVICE		PACKAGE	DEVICE		PACKAGE		
Height	mm	592		655	650		713		
Length	mm	314		367	363		416		
Depth	mm	245		280	245		280		
Weight	Kg	10,60		12,60	12,10		14,50		

Note: relative cold water temperature of 15 °C

Misure in mm

	A	B (Ø)	C	D	E	F	G	H
11p	592	110	101	245	314	97	54	83
14p	650	130	101	245	365	117	74	103

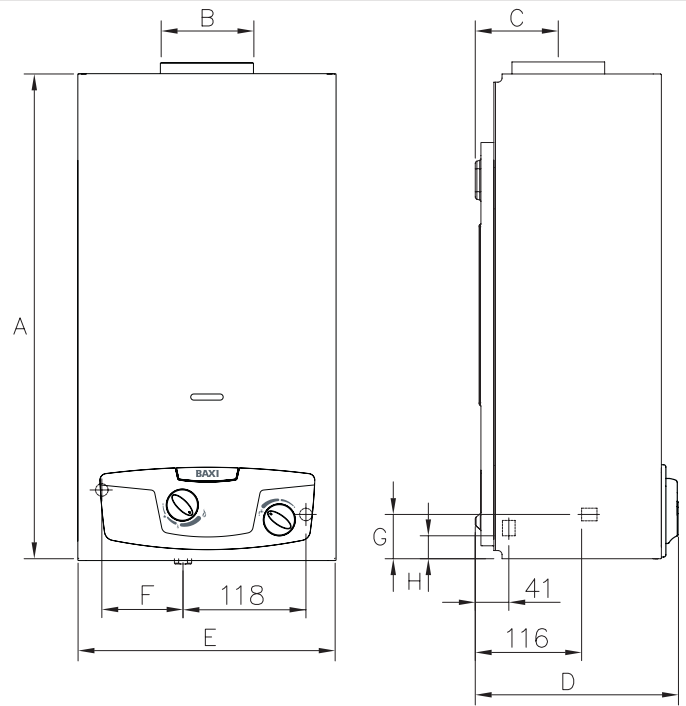

Fig. 1

- 1 Flue gas release safety device
- 2 Release hood
- 3 Heat exchanger
- 4 Ignition electrode
- 5 Burner
- 6 Hydraulic valve
- 7 Temperature regulator
- 8 Gas valve
- 9 Gas input
- 10 Gas adjustment screws
- 11 Piezoelectric button
- 12 Gas control
- 13 Devices pressure
- 14 Ignition electrode
- 15 Thermocouple

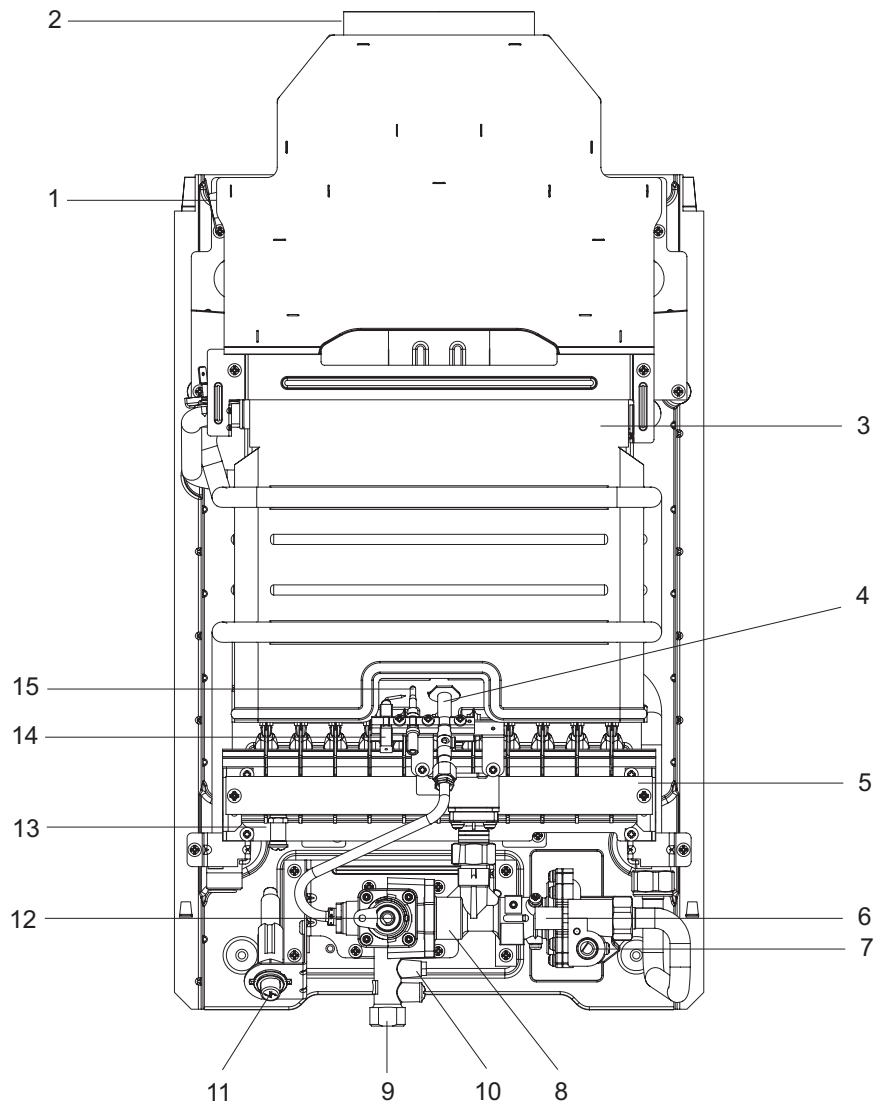

Fig. 2

2. INSTALLATION

2.a Regulations

The use of gas devices is controlled by precise regulations. It is essential to observe regulations in force.

Installation of liquid petroleum gas (L.P.G) must comply with all the distributor's requirements and those of the regulations.

2.b Wall mounting

Warning

Do not install this device in an area that contains dust, greasy vapour and/or corrosive elements.

- The device must be installed on a suitable wall surface in proximity to a fume disposal flue
- It is vital to leave the minimal distances around the device as shown in fig 3 to allow for maintenance operations to take place.

Location

The water heater must not be tightly placed in an enclosure or slot, it should have an adequate flow of air around it

- The water heater must not be placed above a kitchen or other cooking devices that might deposit grease vapour on its exterior leading to corrosion
- Surfaces that sensitive to heat (e.g. wood) must be protected using appropriate insulation.
- Fig. 4 displays the dimensions necessary for wall mounting

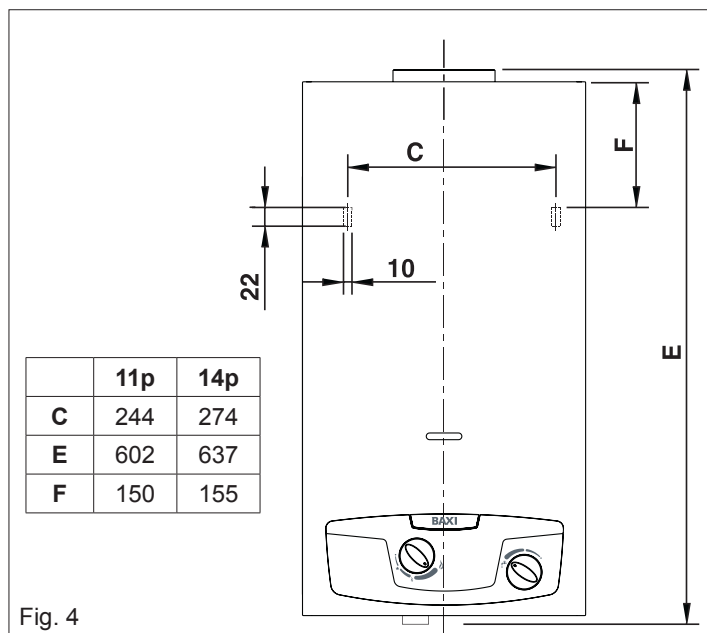
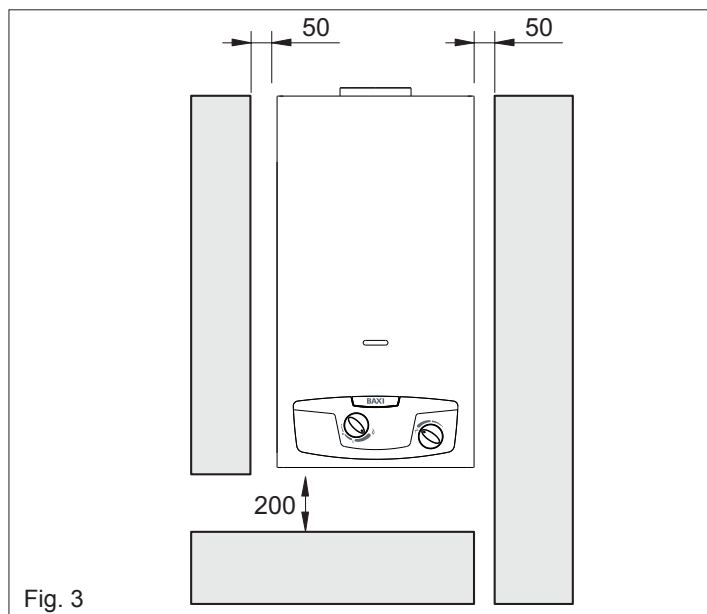

2.c Room ventilation

The installation of the water heater must comply with regulations in force including any updates. See paragraph 2.a

Warning: This device can only be installed in venues that are permanently ventilated according to regulation in force.

Air circulation

It is vital that areas where gas devices are installed (type B) have access to the amount of air necessary for the regular combustion of gas as well as the ventilation of the venue.

- It is prohibited to use an extractor fan, fireplaces and other similar devices at the same time as the water heater
- The area where the water heater is installed must have a regular flow of air for ventilation.

Air flow

The flow of air must occur by the following means:

- Permanent openings in the wall that lead outdoors
- Single or collective ventilation ducts.

The air used for ventilation must be taken directly from an outside location, that is far from sources of pollution.

Indirect ventilation from adjacent areas are permitted with the following limitations:

- The adjacent area is equipped with direct ventilation
- The devices within the area to ventilate are connected to a waste duct
- The adjacent area does not contain a bedroom and is not a common area;
- The adjacent area is not a fire hazard such as a storage area for flammable materials, garage etc.
- The adjacent area is not lower than the area to ventilate as this might lead to an opposing draught (this can be caused by other devices that operate on the basis of combustion, a fireplace or any suction device that have not been given an adequate air supply)
- The air flow from the adjacent area occurs freely through permanent openings.

2.d Gas Connection

See paragraph 2.a

Determine the pipe diameter according to current regulations. Before installing the device blow in the gas pipe to eliminate any residue from its manufacturing. Connect the water heater to the internal system's gas pipes and place a tap above the device for the halting and release of gas.

The water heaters that are powered by tanks of L.P.G. gas with regulation and interception devices, must be connected correctly so to guarantee the safety of persons and the surrounding area.

Follow all related regulations.

When initially installing the device qualified persons must perform the following tests:

- Check that the internal and external parts of the gas supplying device are sealed;
- check that the gas quantity supplied is equal to that required by the device;
- check that the device receives the type of gas it is manufactured to process;
- check that the gas supply pressure does not go beyond the maximum pressure values displayed on the information plate;
- check that the gas supply system supplies the necessary amount of gas to the device and that it is equipped with all the necessary safety devices prescribed by current regulations.

If the user is absent for a lengthy period, turn off the main gas supply tap.

Do not obstruct the area's ventilation openings where the device is installed to avoid dangers such as the build up of toxic and explosive substances. Do not utilize gas tubes to earth electrical devices.

2.e Water connection

Connect the water heater to the water supply and insert a tap to intercept the water above the device. From the front, the cold water input is on the right and the hot water output is on the left.

- ⚠ Insert the filter into the water valve input fitting.
- ⚠ Remove the plastic nut from the hot water output fitting before connecting it to the water supply.

Ensure that the tubes of your water system are not used to earth your electrical system or telephone, they are absolutely inappropriate for performing this task.

In a short amount of time this can damage tubes and the device.

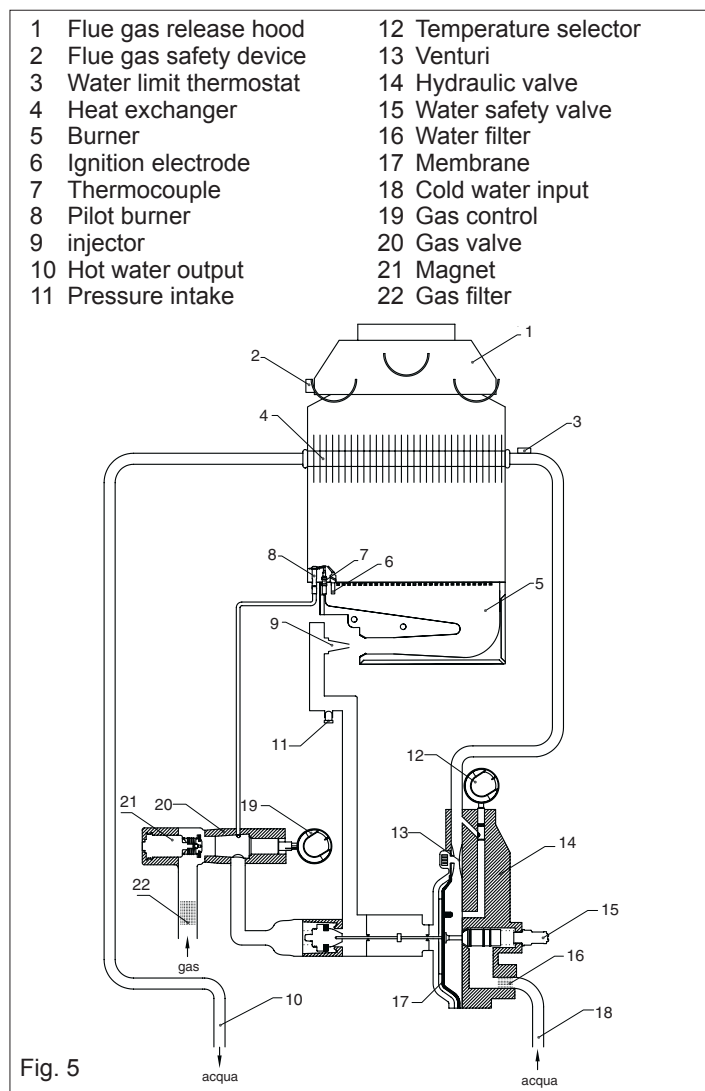

2.f Disposal of waste product

This B11BS water heater is supplied with a device for releasing flue gas.

For output of combustion by-products refer to the regulations in force including any updates. See paragraph 2.a

The gas devices with an attachment for a waste gas flue must be connected directly to properly working chimney or flue pipe; only if these devices are not present is it then permitted to release gases directly outside.

The fitting of devices to a chimney or flue pipe must occur via a smoke channel. Smoke channels must be connected to a chimney or a smoke channel in the same or adjacent area to where the device is installed and must be made of materials resistant to mechanical strain, heat and the effects of combustion by-products and their condensation. The flue gas temperature must always be above condensation temperature in all points of the smoke channel regardless of external conditions.

FLUE GAS RELEASE SAFETY DEVICE

The product is equipped with a series of flue gas release safety

devices. The device ensures the correct release of combustion by-products; the flow of combustible gas to the release conduit and the smoke channel.

The safety device contains a “thermostat” that is connected to the thermocouple. The safety device’s intervention blocks the thermocouple and blocks the flow of gas to the main burner as well as the pilot flame. The safety device can be triggered by the partial or total obstruction of the release conduit or the smoke channel.

The obstruction can be caused by internal or external influences, for example:

- a release conduit with an inadequate configuration,
- the reduced diameter of the release conduit
- excessive direction changes (curves)
- counterslope.

The above circumstances obstructs the flow of flue gas to the outside. The safety device blocks the device, not allowing the flue gas to fill the area where the device is installed. To again use the product it is necessary to follow the instructions in the paragraph “OPERATION”

If the device or its electrical connections breaks down, the machine operation is blocked. If the machine is constantly blocked as a result of the flue gas safety device, it is necessary to request the assistance of a qualified technician according to law in force, to check the correct release of flue gas through the release conduit and/or the smoke channel, according to the installation regulation.

It is highly prohibited to attempt to modify or remove the flue gas safety device; this risks the safety of the user and persons in the area.

Only a qualified technician who is authorised by the manufacturer can meddle with the safety device in order to check it’s functionality or to substitute it if necessary.

If it is necessary to replace the device it is vital to only use “original parts” supplied by the manufacturer since it has been designed, studied and regulated to be fitted with the water heater.

2.g Gas transformation

Transforming the product so it may receive a different type of gas can be easily performed even while it is mounted. The instructions for transforming and regulating the product to receive various types of gas are below.

This operation must be performed by qualified personnel according to law in force.

TRANSFORMATION FROM METHANE TO LPG

Transforming the product so it may receive a different type of gas can be easily performed even while it is mounted.

Before any operation ensure that the gas supply is switched off.

I – SUBSTITUTION OF THE PILOT INJECTOR

- Disconnect the pilot flame tube (fig. 6)
- remove the pilot injector
- insert the injector and seal contained in the transformation kit (fig. 7),

II – SUBSTITUTION OF THE BURNER INJECTORS

- Remove the screws that hold the pilot flame in position (fig. 8)
- Remove the nut that holds the burner in place (fig. 9)
- Remove the screws that hold the diffuser in place (fig. 10)
- Unscrew the diffuser
- Unscrew the injectors and substitute them with those found in the transformation kit

III – SUBSTITUTION OF THE MODULATION VALVE

- Loosen the cold water entry ramp nut on the exchanger
- Remove the 4 screws (B) of the gas valve (fig. 11)
- Separate the water/gas valve set
- Extract the large spring and the small spring/modulation valve set (fig. 12)
- Substitute the modulation valve with the one in the kit
- Insert the valve and the large spring, taking care with the direction of the insertion (fig. 14) and making sure that the drilled

spring guide disc is in its correct position (fig. 13)

- Remount the diffuser attaching it to the upper hole

IV – DISABLING THE PRESSURE REGULATOR

- Remove the protective lid
- Regulate the supply calibration screws so that the maximum amount of gas can pass (disk completely horizontal)

⚠ After regulating seal the lid with paint, lacquer or other such materials.

Note: It is necessary to use a pressure regulator that operates at 30 mbar for Butane Gas and at 37 mbar for Propane Gas. The above values must be measured using a barometer connected to the devices pressure entrance.

TRANSFORMATION FROM LPG TO METHANE GAS

Execute operations I, II and III described above

IV – ENABLING THE PRESSURE REGULATOR

- Remove the protective lid
- Regulate the pressure screws so that the burner reaches the pressure levels indicated on the technical data on page 4 .

Note: ensure that the gas pressure is at 20 mbar.

⚠ After regulating seal the lid with paint, lacquer or other such materials.

⚠ Check that all the disassembled parts are perfectly sealed once the device is operational using a soapy solution.

⚠ **WARNING – IMPORTANT** Write on adhesive paper “device transformed”, including the date of the operation, the name and signature of the person who performed the transformation and attach it to the device near the older information plate. In addition attaché the “Transformed Gas to...” sticker. Attach it to the device over the previous similar sticker, on the frontal part of the hood.

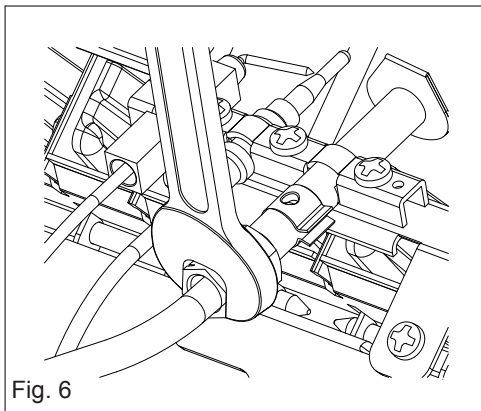

Fig. 6

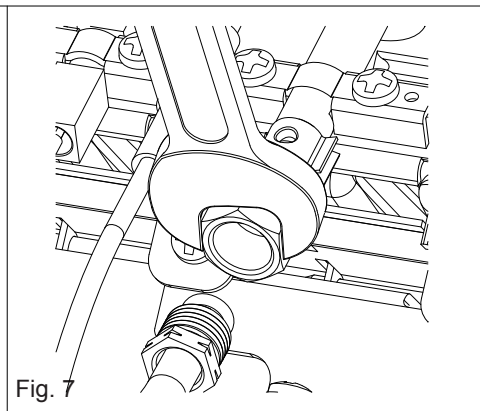

Fig. 7

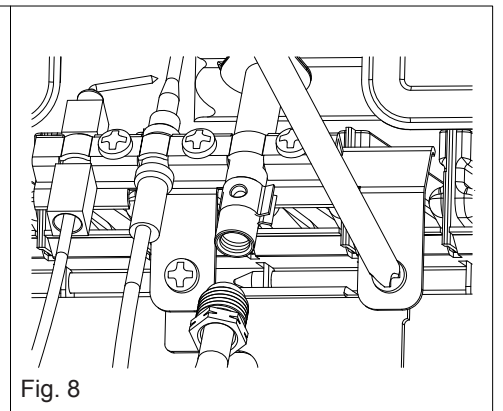

Fig. 8

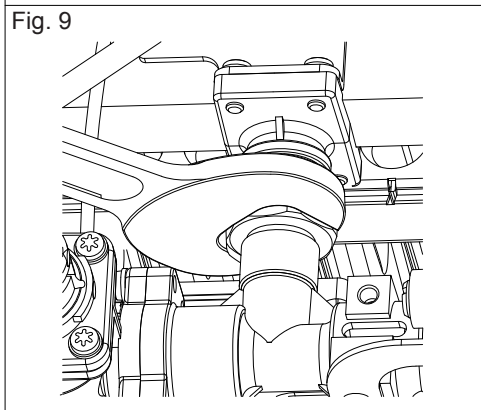

Fig. 9

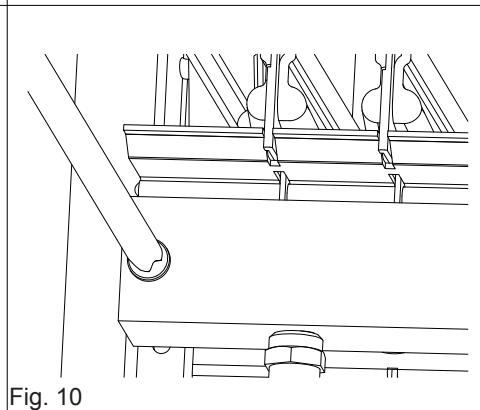

Fig. 10

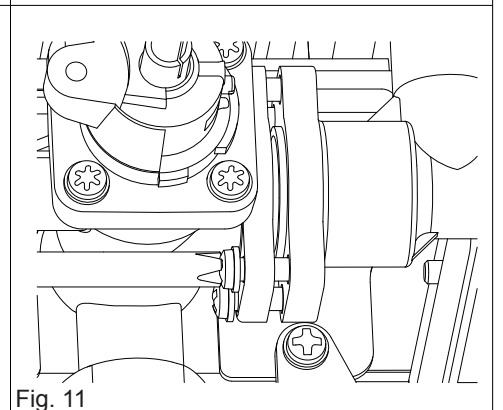

Fig. 11

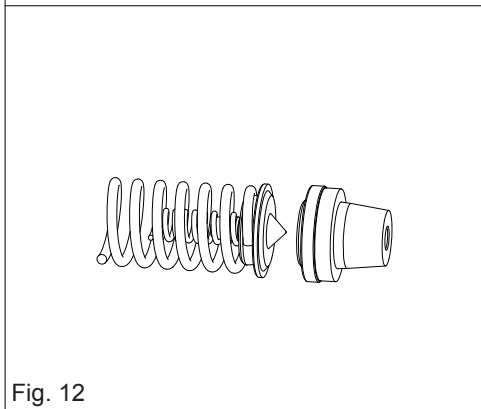

Fig. 12

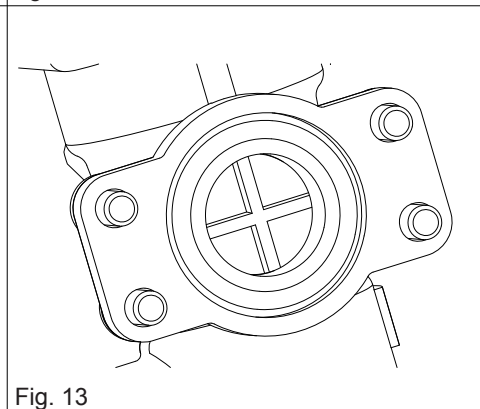

Fig. 13

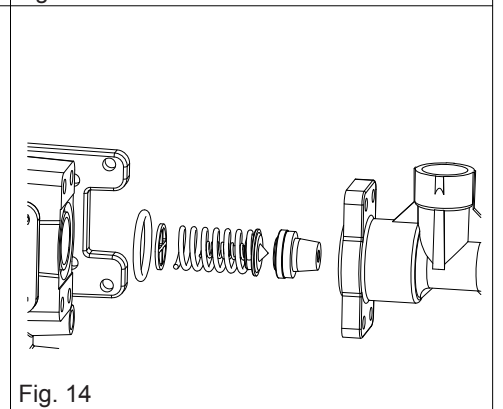

Fig. 14

3. OPERATION

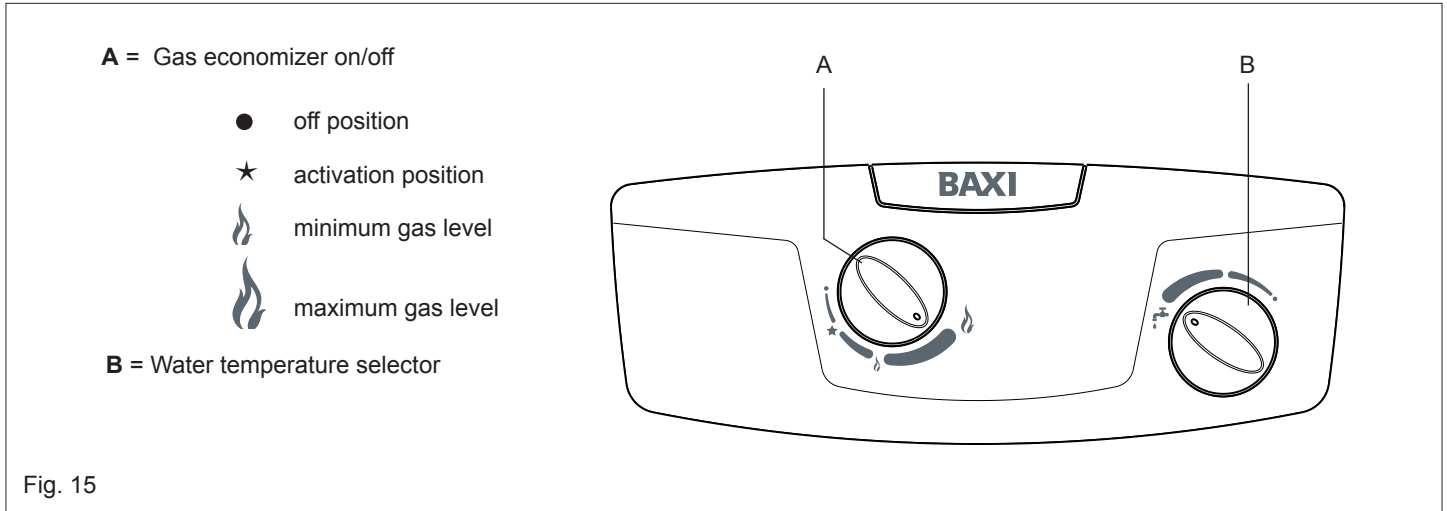

Fig. 15

3.a Function

The water heater is used for the production of instant hot water. The removal of hot water can be performed by multiple taps. By turning on the relative tap, the main burner switches on heating the water that passes.

These devices with a modifiable flame are particularly suited for usage with mechanical mixers and thermostats.

This water heater, in contrast with other water heaters with a fixed flame, has a modulation valve to optimise the water heaters operation. It allows for the water to be heated using less water pressure and gas by modulating the flame according to the amount of water used, maintaining the water extracted at a constant temperature.

The water heater uses automatic variation that is “PROPORTIONAL”, able to change the gas consumption (modulating the flame) to respond to the amount of water extracted.

Model 11p: for the extraction of 2.5 to 5.5 l/m the temperature of the water supplied remains at 60°C, (in this case the has valve supplies the burner with the necessary quantity of gas proportional to the water supplied), above 5.5 l/m to 11 l/m the water temperature varies from 60°C to 40°C.

Model 14p: for the extraction of 2.5 to 7 l/m the temperature of the water supplied remains at 60°C, (in this case the has valve supplies the burner with the necessary quantity of gas proportional to the water supplied), above 7 l/m to 14 l/m the water temperature varies from 60°C to 40°C.

3.b Usage

Ensure that the gas tap and all water taps are switched off

- Turn on the Main gas supply tap or that of the gas tank if using Liquefied Petroleum Gas (L.P.G.)
- Open the gas tap, not supplied with the device, placed immediately before the water heater on the gas input pipe
- Rotate knob A to the on position (★), press the knob down all the way and keep it pressed
- Press the piezoelectric button (positioned on the left side of the water heater) until the spark ignites the pilot flame. When it ignites keep the knob A pressed for 20-30 seconds. If the flame does not ignite repeat the operation until the flame remains on
- Rotate Knob A towards the large flame (🔥), during rotation it is necessary to keep the knob pressed down lightly until the final position is reached
- From this moment the device is able to produce hot water on request. Opening the hot water tap causes the main burner to be ignited, and inversely, by closing the hot water tap the main burner is switched off; but the pilot flame remains switched on for future requests
- If the main burner or pilot flame is accidentally turned off, the gas valve automatically blocks the output of gas within 60 seconds so to avoid any danger. To return the device to an operational mode, repeat the steps above.

The device is built to function with normal water pressure; in addition a temperature selector **B** is also supplied.

Rotate the knob completely to the left to obtain the maximum water output or completely to the right for the minimum water output.

The machine is switched off by rotating knob **A** to the (● OFF) position.

When the water heater is not used for long periods close the gas supply tap or the LPG gas valve on the tank.

For the best operational results it is recommended to have a qualified technician service the machine at least once a year.

Gas economizer

The device is equipped with a gas economizing device which is used to choose the temperature of the water so it may be supplied at the temperature necessary while saving gas.

The economizer is activated by rotating the knob (**A**) in-between the minimum (small flame 🔥) and maximum (large flame 🔥) position.

Using the economizer limits the amount of heating when the hot water usage is modest (water supplied is already warm or there is a reduced usage, for example in summer).

DANGER OF FREEZING

If there is a possibility that the area where the device is stalled could reach below 0°C, the device must be emptied of all water contained.

4. MAINTENANCE

To maintain the machine at maximum efficiency, have qualified personnel perform a maintenance check at least once a year.

Before cleaning or performing maintenance, opening or disassembling the panels, switch off the device and turn off the gas supply. Check the main burner and the pilot flame, the ignition electrode, the safety valve and that there is no leakage. Check that there is nothing obstructing the passages within the exchanger smoke channel.

To clean the outside of the panels utilize a cloth with soap and water.

Do not use solvents, powders or abrasive sponges.

Do not clean the device and/or its parts with flammable materials (e.g. petrol, alcohol, diesel etc.).

4.a Removing the casing (Fig. 16)

To remove the outer casing follow the steps below:

- Remove the selector Knobs (A and B)

- Remove the screws (C)
- Shift the casing upwards to free it from the upper and lateral hooks
- Shift the casing forwards
- To reinsert the casing, follow the above steps in reverse order

4.b Troubleshooting: problems and solutions

For the best functioning of the water heater, to prolong its lifetime and ensure that it is always safe, ensure that it is inspected at least once a year by a trained professional. The trained professional is to perform the following maintenance operations:

- Remove any rust from the burner
- Remove any deposit on the glow plug by the electrode
- Clean the combustion tank
- Check the ignition, switching off and general functionality of the device
- Check that the gas and water tubes and connections are sealed

Warning: the following repair instructions are only to be performed by qualified and authorized technicians.

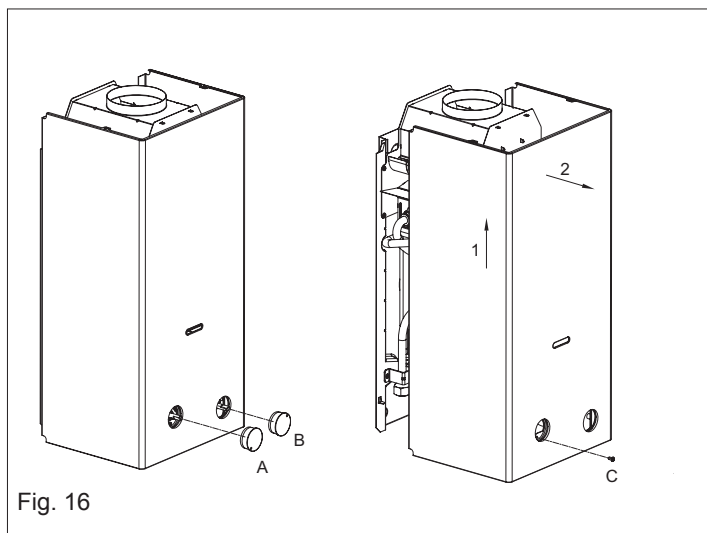



Fig. 16

PROBLEM	CAUSE	SOLUTIONS
There is no spark	<ul style="list-style-type: none"> - Exhausted battery - Electrical cable of device is disconnected - Electrical card is broken - There isn't sufficient water pressure - The membrane is broken - The electrode is damaged 	<ul style="list-style-type: none"> - Substitute - Insert - Test, substitute - Repair the device to guarantee pressure, rotate the selector knob all the way to the right - Substitute - Substitute
The pilot does not switch on when there is a spark	<ul style="list-style-type: none"> - Safety device broken - No gas supply - Air in the gas tubes 	<ul style="list-style-type: none"> - Substitute - Open the gas tap - Release gas
The burner does not switch off when the water turns off	<ul style="list-style-type: none"> - Grime on the gas shutter - Valve piston or stem is locked in open position - Micro lever is locked in open position - If an LPG supply, check the gas pressure 	<ul style="list-style-type: none"> - Test, clean - Disassemble, clean and eventually substitute - Test - Regulate and if necessary substitute the tank pressure regulator
The exchanger blade becomes dirty in a small amount of time	<ul style="list-style-type: none"> - Poor draught or dusty surroundings - Yellow flame - Excess gas consumption 	<ul style="list-style-type: none"> - Check the smoke channel efficiency - Check the gas type and clean the burner - Check and regulate
There is a smell of gas	<ul style="list-style-type: none"> - Due to the loss of gas in the tubes, check the tubes and find the leak 	<ul style="list-style-type: none"> - Do not activate electric switches or any object that produces sparks in local area
There is a smell of gas	<ul style="list-style-type: none"> - It can be caused by obstruction in the flue gas circuit - Excess gas consumption 	<ul style="list-style-type: none"> - Check the efficiency of the smoke channel and the flue gas conduit - Check and regulate

5. SERIAL NUMBER PLATE

BAXI	
 0694/00 0694CP4791	
BAR CODE	
N°	00000000000 0000
Category Nominal feed pressure	IT-ES-PT: II2H3+ G20: 20 mbar G30/G31: 28-30/37 mbar
Baxi 11p	
Pn = 19.0 kW	
Qn = 21.8 kW	
Pm = 7.5 kW	
Qm = 9.0 kW	
P H ₂ O max = 10.0 bar	
Appliance type	B11BS
Made in: IR	

Pn = Nominal power usage
 Qn = Nominal thermal range
 Pm = Minimal power usage
 Qm = Minimal thermal range
 P H₂O max = Maximum water pressure

BAXI